



Torque tester SENSOTORK®

7707-2W

Art.No. **96521072**

GTIN **4018754155781**

Model **7707-2W**

Label.

Electronic workshop tester SENSOTORK No.7707-2W ²⁾ N·m

Features.

Electronic testing device for torque wrenches, consisting of:

- Transducer (patented)
- Bracket
- Display device (DBGM)
- Stand for display device (with 1.5 m cable)
- Spiral cable
- Power supply (110 V-230 V with interchangeable socket adapters) or direct connection to 12 V car electrical system
- Square drive adapter (No. 7707-2W, No. 7707-2-1W, No. 7707-2-2W, No. 7707-3W)
- Mounting kit for horizontal and vertical test positions
- For clockwise and counter-clockwise measurements
- Measurement units: N·m, ft·lb, in·lb
- The easily interchangeable transducers are attached to the holder with a QuickRelease safety lock.
- Low transverse forces due to flat transducers
- Automatic detection of transducers
- Versatile and easy to use with horizontal or vertical checking positions and variable display positioning
- Additional stand with 1.5 m cable to hold the display for better optical tracking when testing long torque wrenches
- Particularly large measurement range from about 2% to 100% of the nominal value
- Software No. 7759-4 including USB adapter and phone jack cable allows the measured values to be transmitted to a PC (no additional external power source, power from the PC)
- When recalibrating the individual transducers, the test equipment remains operational on site
- Wide range of applications (-20°C to +60°C)
- Complies with DIN 51309, Class 2 and DKD-R 10-8
- With certificate
- Delivered in a sturdy plastic box

QuickRelease

Quick change and secure hold of the various transducers with the QuickRelease safety lock

Interchangeable square adapters:

Interchangeable square adapters for different drive sizes are integrated in the mounting block for easy access

"



Technical Drawing.

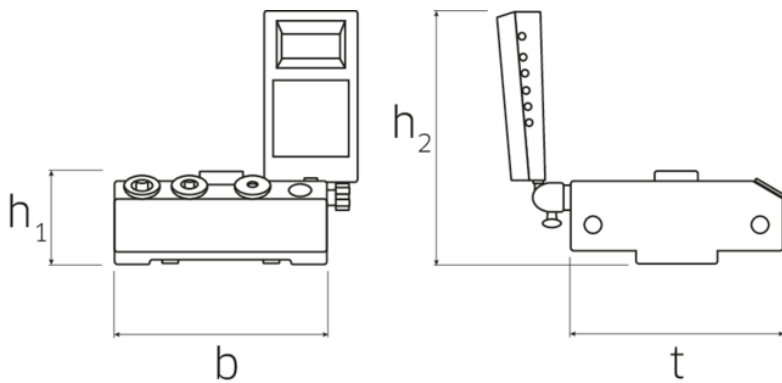

Technical Attributes.

Width mm (b)	180 mm
Weight with box	10300 g
Height mm (h)	170 mm
Height mm (h1)	79 mm
Height mm (h2)	215 mm
Female square drive [inches]	3/8 "
Measuring range N-m	2-100 N·m
No.	7707-2W ²⁾
t	180 mm

Logistics data.

Length (IFS)	430
Width (IFS)	340
Height (IFS)	170
Length (packed, mm)	430
Width (packed, mm)	340
Height (packed, mm)	170
Volume (packed, mm)	24.854 dm ³
Artikelnummer	96521072
Weight (gross, kg)	10,080
Weight PAP (kg)	0,016
Weight PVC (kg)	0,000
GTIN	4018754155781
Country of origin	GERMANY
Region of origin	Nordrhein-Westfalen
WEEE/Electrical Act	Kleingeräte B2C

Customs tariff no. 90318080

Numbers of content units per order units 1

Weight 7025 g

Parts list.



52100051
Recording body



81320002
Plastic case



52100050
Display unit



11030010
Adapter



52110052
Spiral cable



52110056
Mains adaptor



52110051
Jack cable



52100059
Transducer in case



52100058
Transducer in case

Variants.

Artikelnummer	Article number (ERP)	Article description (Autom.)	GTIN
96521086	7707-1-3W	Torque tester SENSOTORK No.7707-1-3W ¹⁾ N·m	4018754241958
96521085	7707-1-2W	Torque tester SENSOTORK No.7707-1-2W N·m	4018754241941
96521080	7707N-1W	Electronic workshop tester SENSOTORK No.7707-1W N·m	4018754181148
96521072	7707-2W	Electronic workshop tester SENSOTORK No.7707-2W ²⁾ N·m	4018754155781
96521083	7707-2-1W	Torque tester SENSOTORK No.7707-2-1W ³⁾ N·m	4018754181162

96521084	7707-2-2W	Torque tester SENSOTORK No.7707-2-2W ⁴⁾ N·m	4018754181179
96521082	7707N-3W	Electronic workshop tester SENSOTORK No.7707-3W ⁴⁾ N·m	4018754181155

GTIN-Code.



STAHLWILLE Eduard Wille GmbH & Co. KG

Lindenallee 27 · 42349 Wuppertal · Germany · Phone: +49 202 4791-0 · Fax: +49 202 4791-200
info@stahlwille.de · www.stahlwille.com · Copyright by STAHLWILLE Eduard Wille GmbH & Co. KG, Wuppertal
Copyright by STAHLWILLE Eduard Wille GmbH & Co. KG, Wuppertal