

Service MANOSKOP® torque wrenches w.mount for insert tools

730N/80



Art.No. 50181080
GTIN 4018754239948
Model 730N/80

Label.

Torque wrench service MANOSKOP No. 730N/80 Measuring-R. 160-800N-m Inside square stitch size 22 x 28 mm L. 1178mm

Features.

- mount for interchangeable insert tools
- QuickRelease safety lock
- can be applied for either clockwise or anticlockwise tightening by turning the inserts over
- display deviation value $\pm 3\%$ (size 2; a/2 4 %)

Advantages.

Mount for interchangeable inserts/sockets

Product highlights.



Flexible rod principle.

Mechanical torque wrenches from STAHLWILLE have a wear-resistant trigger system with a flexible rod. In contrast to conventional torque wrenches with spiral springs, the STAHLWILLE system eliminates one key work step: once the fastener has been tightened, it is not necessary to reset the wrench to »0«.



Simple.

Quick adjustment from outside, no disassembly of the torque wrench required, with two adjustment points for the maximum & minimum values.



Clicking.

When the target torque is reached, MANOSKOP® 730N provides a noticeable tactile dual stop signal.

**Clear view.**

Easy-to-read dual scale with colour differentiation between the N·m and ft·lb scales to simplify fine setting.

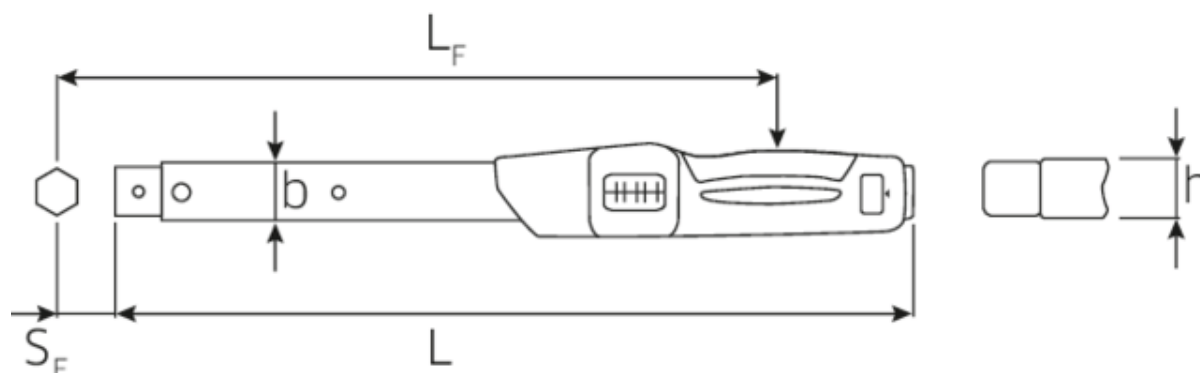
Technical Drawing.**Technical Attributes.**

Width mm (b)	30,6 mm
Fine scale division	5 N·m
Size	80
Size hexagon socket [internal square]	22 x 28 mm
Height mm (h)	25,6 mm
Length mm (L)	1178 mm
LF	1167 mm
Lowest value of measurement range N·m	160 N·m
Measuring range ft·lb	120-600 ft·lb
Measuring range N·m	160-800 N·m
Nominal value N·m	800 N·m
SF	55 mm
Scale division [E1]	100 N·m
Scale division [E2]	25 ft·lb

Logistics data.

Length (IFS)	1160
Width (IFS)	50
Height (IFS)	50
Length (packed, mm)	1160
Width (packed, mm)	50
Height (packed, mm)	60
Volume (packed, mm)	3.48 dm ³
Artikelnummer	50181080
Weight (gross, kg)	5,500
Weight PAP (kg)	0,000
Weight PVC (kg)	0,042
GTIN	4018754239948
Country of origin	GERMANY
Region of origin	Nordrhein-Westfalen
WEEE/Electrical Act	nicht ear-pflichtig
Customs tariff no.	82041100
Numbers of content units per order units	1
Weight	4825 g

Variants.

Artikelnummer	Article number (ERP)	Article description (Autom.)	GTIN
50181100	730N/100	Torque wrench service MANOSKOP No. 730N/100 Measuring-R. 200-1000N·m Inside square stitch size 22 x 28 mm L. 1363mm	4018754239955
50181080	730N/80	Torque wrench service MANOSKOP No. 730N/80 Measuring-R. 160-800N·m Inside square stitch size 22 x 28 mm L. 1178mm	4018754239948
50181365	730NII/65	Torque wrench service MANOSKOP No. 730NII/65 Measuring-R. 130-650N·m Inside square stitch size 22 x 28 mm L. 911mm	4018754239986
50181065	730N/65	Torque wrench service MANOSKOP No. 730N/65 Measuring-R. 130-650N·m Inside square stitch size 14 x 18 mm L. 890mm	4018754163991
50181040	730N/40	Torque wrench service MANOSKOP No. 730N/40 Measuring-R. 80-400N·m Inside square stitch size 14 x 18 mm L. 607mm	4018754139552
50181020	730N/20	Torque wrench service MANOSKOP No. 730N/20 Measuring-R. 40-200N·m Inside square stitch size 14 x 18 mm L. 467mm	4018754139545
50181012	730N/12	Torque wrench service MANOSKOP No. 730N/12 Measuring-R. 25-130N·m Inside square stitch size 14 x 18 mm L. 421mm	4018754139538
50181010	730N/10	Torque wrench service MANOSKOP No. 730N/10 Measuring-R. 20-100N·m Inside square stitch size 9 x 12 mm L. 386mm	4018754139521
50181005	730N/5	Torque wrench service MANOSKOP No. 730N/5 Measuring-R. 10-50N·m Inside square stitch size 9 x 12 mm L. 330mm	4018754139514

GTIN-Code.





STAHLWILLE Eduard Wille GmbH & Co. KG

Lindenallee 27 · 42349 Wuppertal · Germany · Phone: +49 202 4791-0 · Fax: +49 202 4791-200
info@stahlwille.de · www.stahlwille.com · Copyright by STAHLWILLE Eduard Wille GmbH & Co. KG, Wuppertal
Copyright by STAHLWILLE Eduard Wille GmbH & Co. KG, Wuppertal